



 **adf**  
fabricante equipamentos térmicos



PT

Desde o início da sua actividade em 1976 que, a ADF se dedicou ao fabrico de soluções de aquecimento a biomassa com, qualidade, robustez e design inovador. Hoje, com o conhecimento acumulado, e desejo contínuo de inovação, a ADF desenvolve e fabrica equipamentos de elevada qualidade. Desempenho, design e segurança são atributos que irá encontrar nos nossos equipamentos, hoje adquirir um equipamento ADF é mais do que garantir o aquecimento do lar, é decoração, conforto, segurança e bem-estar. Fruto do nosso profissionalismo, todos os nossos equipamentos cumprem com os requisitos estabelecidos pelas normas europeias.

ES

Desde el comienzo de su actividad en 1976, ADF se dedica a la fabricación de soluciones de calefacción a biomasa con, calidad, durabilidad y diseño innovador. Hoy, con el conocimiento acumulado, y el deseo permanente de innovar, ADF desarrolla y fabrica equipos de alta calidad. Rendimiento, diseño y seguridad son los atributos que se encuentra en nuestros equipos, hoy la compra de un equipo ADF es más que asegurar la calefacción de la casa, es decoración, comodidad, seguridad y bienestar. Con nuestra profesionalidad, todo nuestro equipo cumple con los requisitos establecidos por las normas europeas.

EN

Since the beginning of its activity in 1976, the ADF is dedicated to the manufacture of biomass heating solutions with quality, durability and innovative design. Today, with the accumulated knowledge, and the continuous desire of innovation, ADF develops and manufactures high quality equipments. Performance, design and safety are attributes that will find in our equipments, today purchasing ADF equipments is more than ensuring the heating of the home, is decoration, comfort, safety and welfare. With our professionalism, all our equipment complies with the requirements set by European standards.

FR

Depuis le début de son activité en 1976, l'ADF est dédiée à la fabrication de chauffage à la biomasse avec des solutions de qualité, durabilité et design innovant. Aujourd'hui, avec les connaissances accumulées, et le désir continu d'innovation, ADF développe et fabrique des équipements de haute qualité. Performance, design et sécurité sont des attributs qui se trouve dans nos équipements, aujourd'hui l'achat d'équipements ADF est plus que d'assurer le chauffage de la maison, est la décoration, le confort, la sécurité et le bien-être. Grâce à notre professionnalisme, tous nos équipements sont conformes aux exigences fixées par les normes européennes.

LEGENDA ·····LEYENDA ·····LEGEND ·····LÉGENDE



Dimensões (mm) (largura x altura x profundidade)  
Dimensiones (mm) (ancho x altura x profundidad)  
Dimensions (mm) (width x height x depth)  
Dimensions (mm) (largeur x hauteur x profondeur)



Diâmetro Saída de fumos (mm)  
Diámetro de la Chimenea (mm)  
Chimney Diameter (mm)  
Diametre de la cheminee (mm)



Peso (kg)  
Peso (kg)  
Weight (Kg)  
Poids (Kg)



Pressão Máxima (Bar)  
Presion Maxima (bares)  
Maximum Pressure (Bar)  
Pression Maximale (Bar)



Potência Nominal (kW)  
Potencia Nominal (kW)  
Rated Output (kW)  
Puissance Nominale (kW)



Classe Energética  
Clase de Eficiencia  
Efficiency Class  
Classe D'Efficacite



Capacidade Volumétrica (litros)  
Volumen de Agua (litros)  
Water Volume (litres)  
Volume D'Eau (litres)



Rendimento (%)  
Rendimiento (%)  
Efficiency Rate (%)  
Rendement (%)



Volume Aquecido (m)  
Volume Calentado Máximo (m)  
Maximum Heated Volume (m)  
Volume Chauffe Maximum (m)



Potência Média da Água (kW)  
Potencia Media del Agua (kW)  
Backboiler Output (kW)  
Puissance Moyenne de L'Eau (kW)

# INDEX



RECUPERADORES DE CALOR  
INSERTABLES  
INSERT FIRE  
FOYERS FERMES

.....

N/NV

595N  
680NV  
820NV  
1000NV

PAG 4/5

NMV

680NMV  
820NMV  
1000NMV

PAG 6/7

DF

820N-DF  
820NMV-DF  
1000NMV-DF

PAG 8/9



AQUECIMENTO DE ÁGUA  
HOGARES DE CALEFACCIÓN  
BACK BOILERS FIRES  
FOYERS CHAUDIERES

.....

CALIDA

CALIDA 70  
CALIDA 100  
CALIDA 100 DUO

PAG 12/13

HYDRO

HYDRO-PRESTIGIO

PAG 14/15



SALAMANDRAS  
ESTUFAS  
STOVES  
POÊLE À BOIS

.....

NM-R

820NM-RS  
820NM-RP  
480 NM-RS

PAG 18/19

NMV S/P

820NMV-S  
820NMV-P  
1000NMV-P

PAG 20/21

NMV DF-P

820NMV-DF-P  
1000NMV-DF-P

PAG 22/23

MILLENIUM

MILLENIUM R  
MILLENIUM II

PAG 24/25

MULTIO

MULTIO S  
MULTIO P  
MULTIO M

PAG 26/27

PANORA

PANORA  
PANORA V  
PANORA C  
PANORA CV

PAG 28/29

NORDICA

NORDICA 595N

PAG 30/31



FOGÕES  
COCINA DE MADERA  
WOOD COOKERS  
CUSINIERE À BOIS

.....

FOGÕES

CLÁSSICO  
RÚSTICO  
PRESTIGIO

PAG 34/35



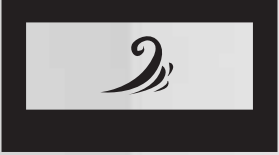

RECUPERADORES DE CALOR  
INSERTABLES  
INSERT FIRE  
FOYERS FERMES







N/NV



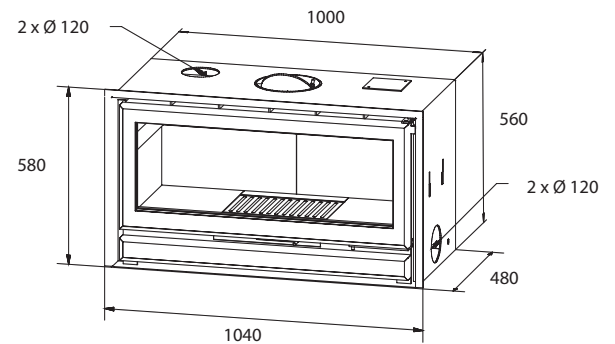
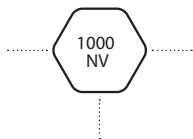
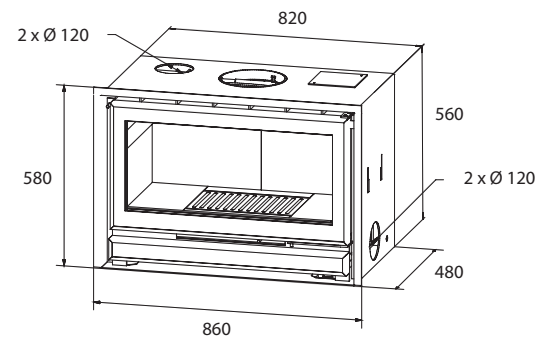
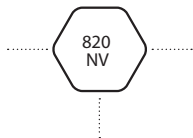
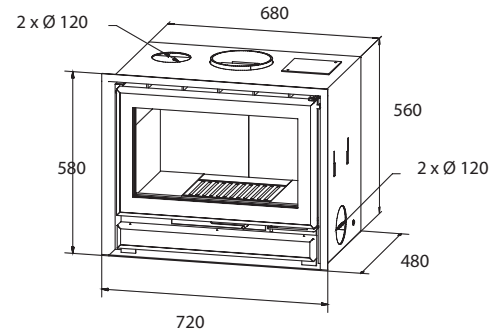
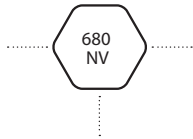
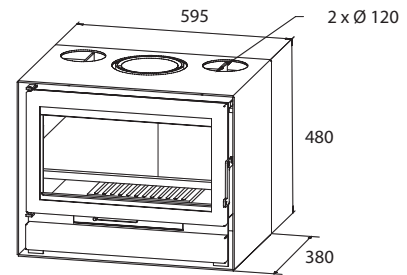
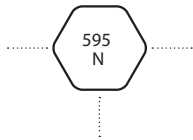

MOD.	MM	KW	kg	lit	mm	M3	KG
595N	595x480x380	10.5	71	180	1	300	115
680NV	680x560x480	11.8	70	180	1	337	135
820NV	820x560x480	12.5	70	200	1	358	158
1000NV	1000x560x480	13.7	67	200	2	390	180



NMV





680  
NMV

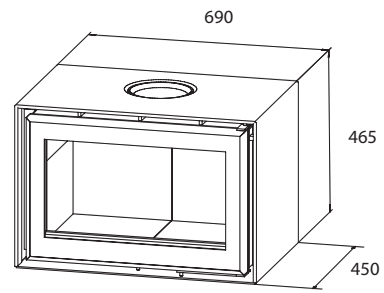

820  
NMV

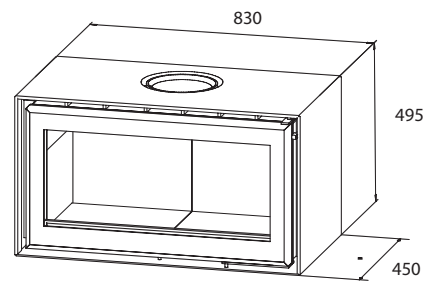

1000  
NMV

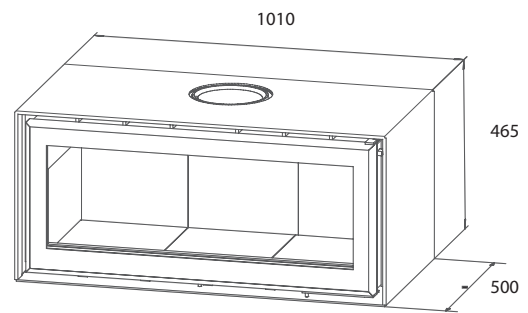

MOD.	MM	KW	%	ø1	Energy Class	dB	KG
680NMV	690x465x450	11.3	68	180	2	322	125
820NMV	830x465x450	12.5	66	200	2	357	148
1000NMV	1010x465x500	13	61	200	2	371	170



DF



820  
N-DF

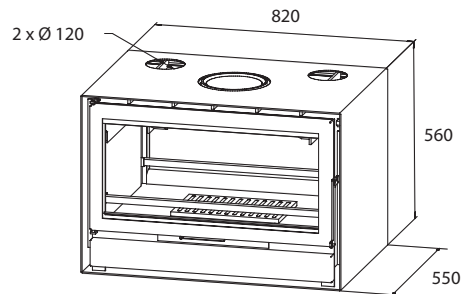

820  
NMV-DF

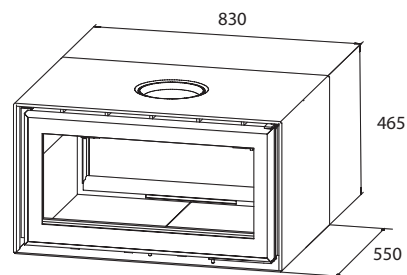

1000  
NMV-DF

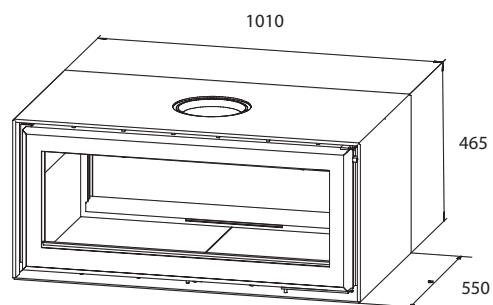

820N-DF	820x560x550	12.5	70	200	1	358	158
820NMV-DF	830x465x550	12.5	66	200	2	358	148
1000NMV-DF	1010x465x550	13	61	200	2	372	170







AQUECIMENTO DE ÁGUA  
HOGARES DE CALEFACCIÓN  
BACK BOILERS FIRES  
FOYERS CHAUDIERE

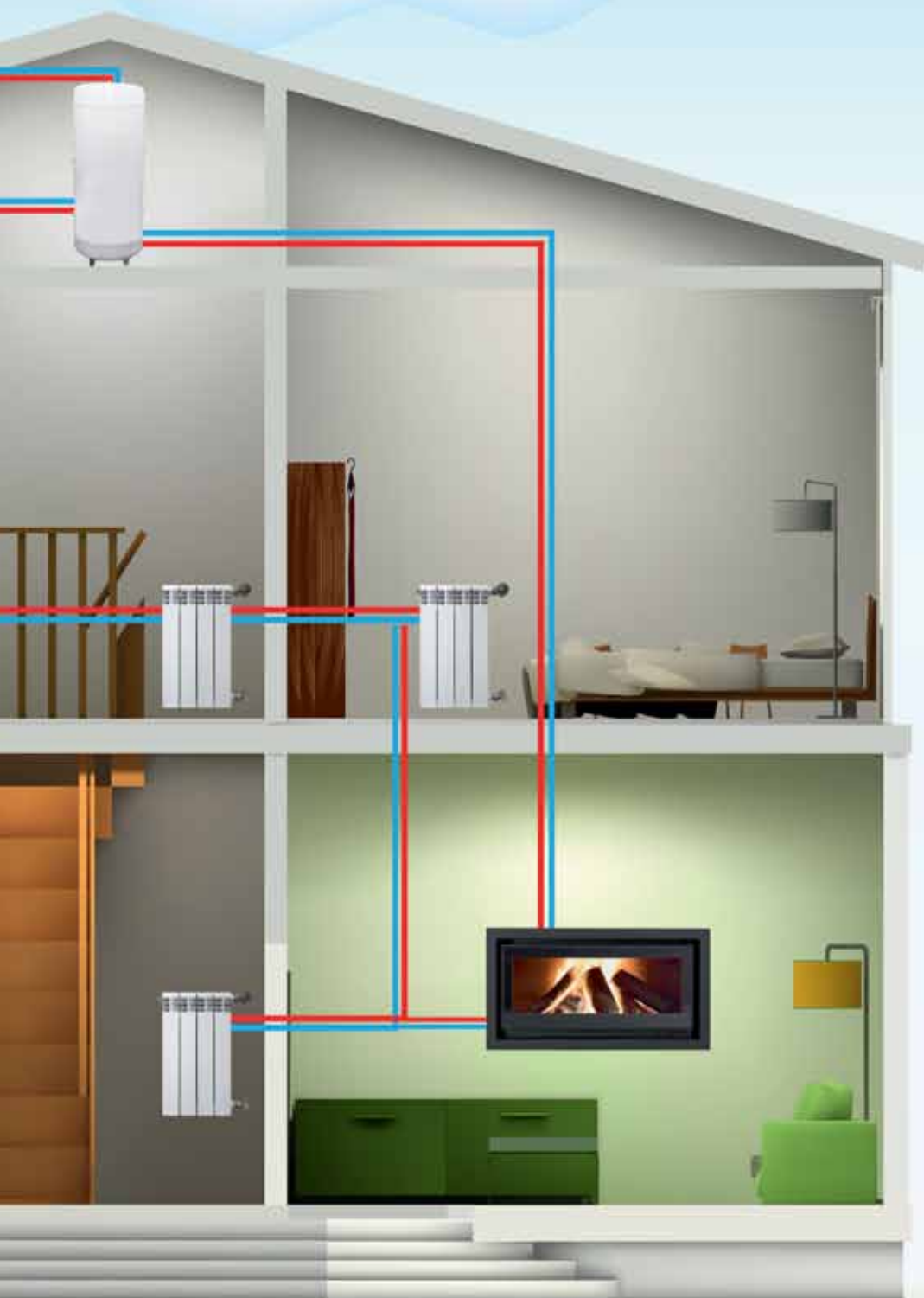



CALIDA



CALIDA  
70

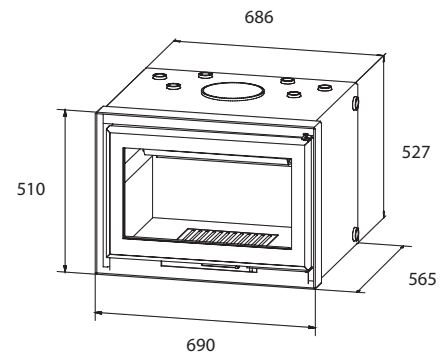

CALIDA  
100

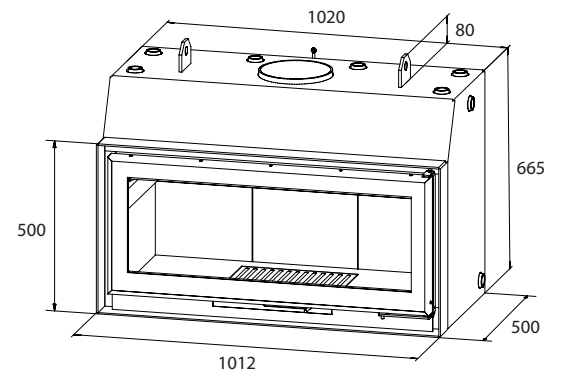

CALIDA  
100 DUO

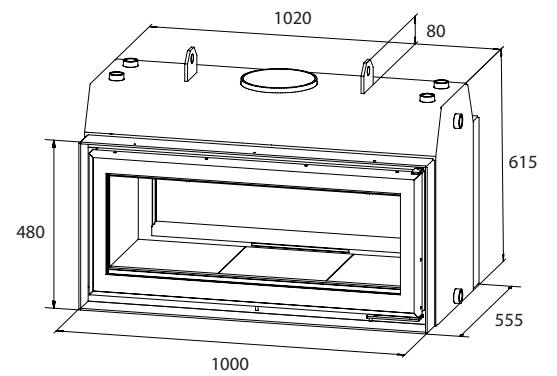

CALIDA 70

690x527x565

21

70

180

1

528

145

50

18

3

CALIDA 100

1020x745x500

26.5

71

200

1

760

255

91

19

3

CALIDA 100 DUO

1020x695x555

23

71

200

1

657

225

70

16.1

3



HYDRO





HYDRO  
PRESTIGIO

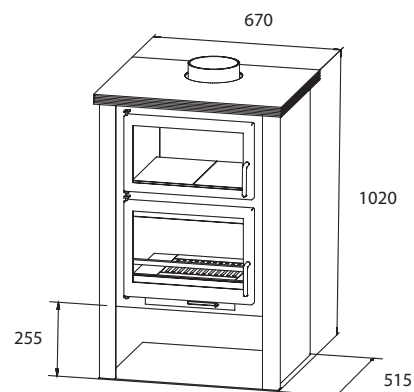

HYDRO-PRESTIGIO



670x1020x515



11.8



75



180



1



338



235



33



9.5



3





SALAMANDRAS  
ESTUFAS  
STOVES  
POËLE À BOIS







NM-R





820  
NM-RS

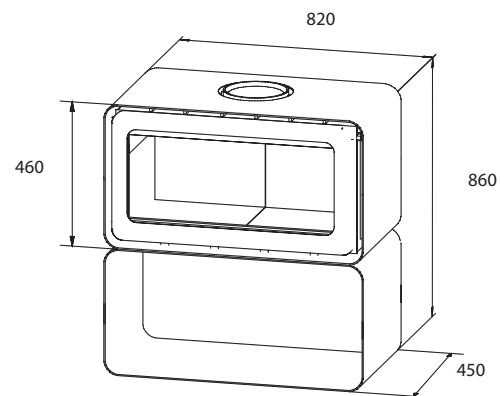

820  
NM-RP

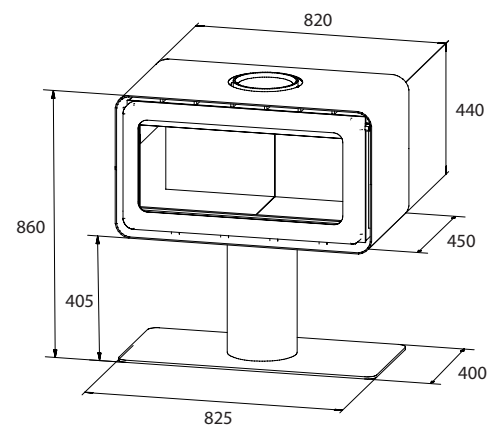

480  
NM-RS

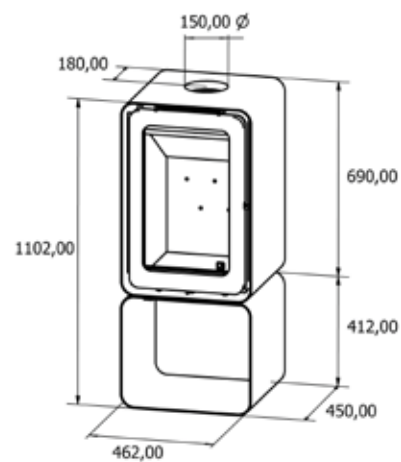

MOD.	MM	KW	%	oli		M3	KG
820NM-RS	820x860x450	12.5	66	200	2	358	178
820NM-RP	820x860x450	12.5	66	200	2	358	180
480NM-RS	460x1100x455	6.7	73	150	1	250	144



NMV  
S/P



820  
NMV-S

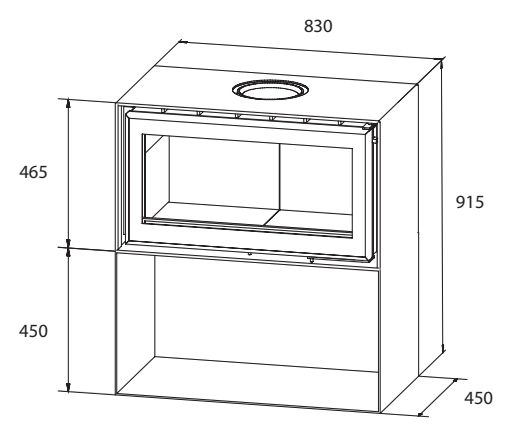

820  
NMV-P

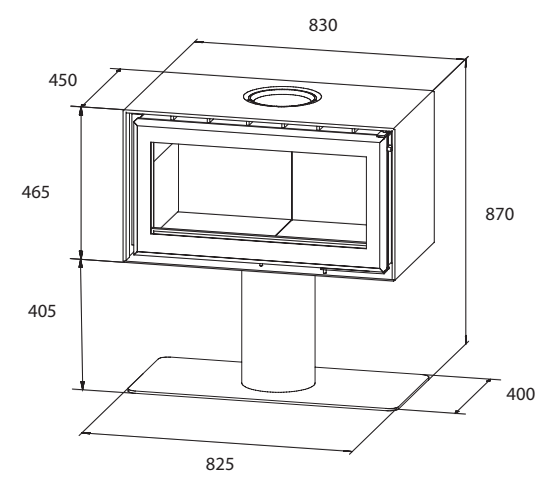

1000  
NMV-P

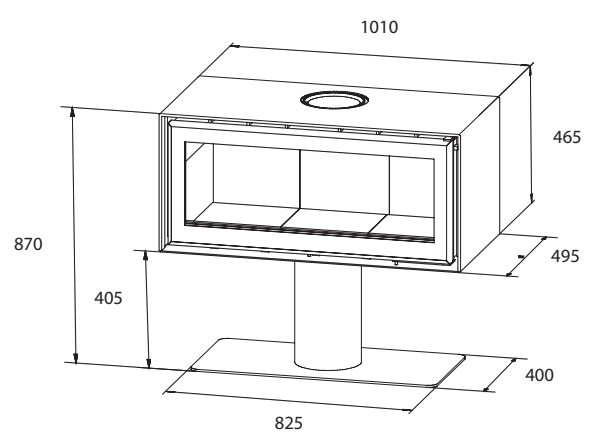

MOD.

MM

KW

%

Ø

+

M<sup>2</sup>

KG

820NMV-S	830x915x450	12.5	66	200	2	357	178
820NMV-P	830x870x450	12.5	66	200	2	357	180
1000NMV-P	1010x870x495	130	61	200	2	371	240



NMV  
DF-P





820  
NMV  
DF-P

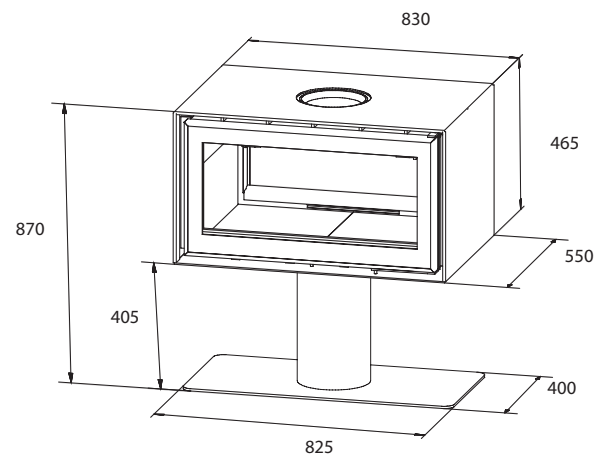

1000  
NMV  
DF-P

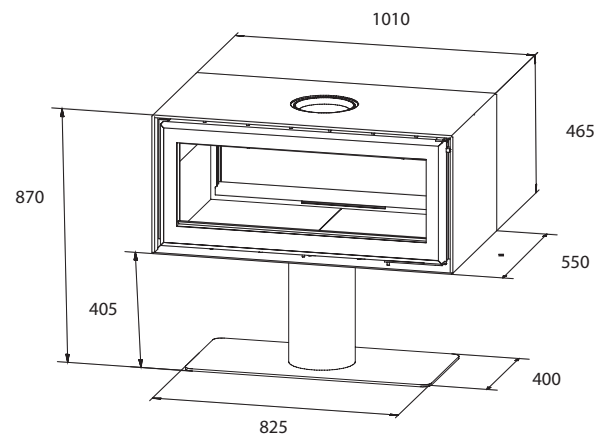

820NMV-DF-P

830x870x500

12.5

66

200

2

357

155

1000NMV-DF-P

1010x870x550

13

61

200

2

371

205



MILLENIUM



MILLENIUM R

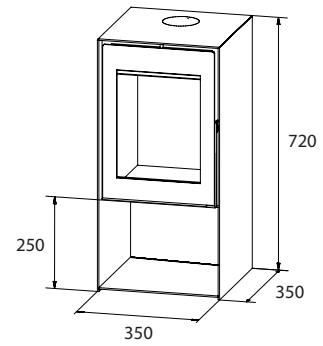

MILLENIUM II

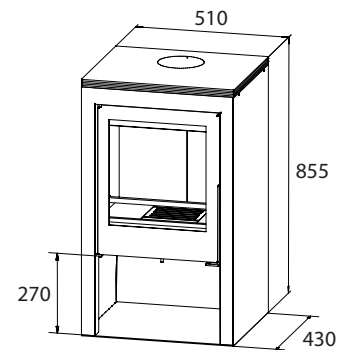

MOD.	MM	KW	%	Øh	←	↑	KG
MILLENIUM R	350x720x350	6.5	73	100	1	172	55
MILLENIUM II	510x855x430	9.1	76	150	1	228	95



MULTIO





MULTIO  
S

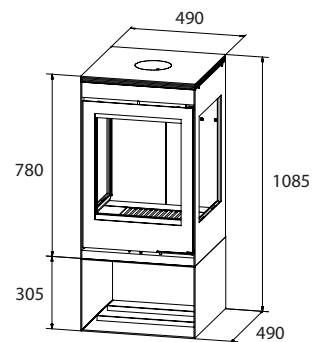

MULTIO  
P

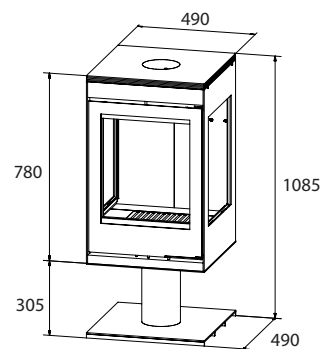

MULTIO  
M

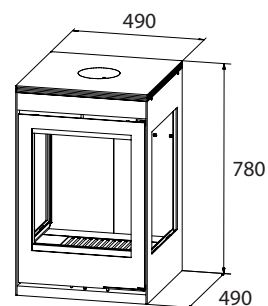

MOD.	MM	KW	Ø	kg	kg	M3	KG
MULTIO S	490x1080x490	9.5	71	150	1	271	165
MULTIO P	490x1080x490	9.5	71	150	1	271	154
MULTIO M	490x775x490	9.5	71	150	1	271	135



PANORA



PANORA

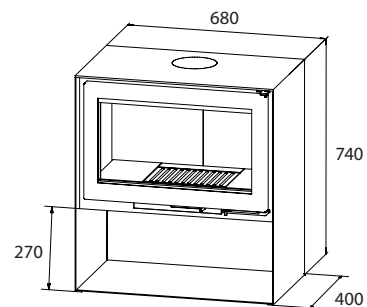

PANORA V

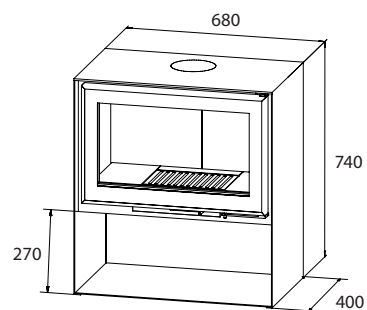

PANORA C

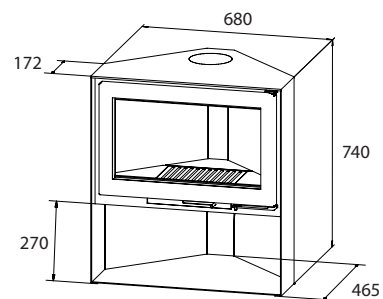

PANORA CV

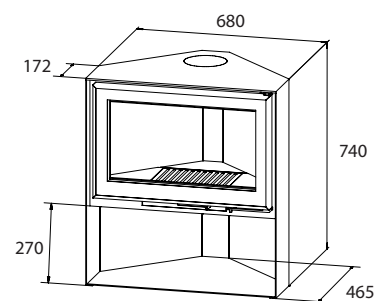

MOD.	MM	KW	%	Ø	Energy efficiency	M3	KG
PANORA	680x740x400	11.3	68	150	2	322	115
PANORA V	680x740x400	11.3	68	150	2	322	115
PANORA C	680x740x465	10.2	68	150	2	295	91
PANORA CV	680x740x465	10.2	68	150	2	295	91





NORDICA





NORDICA  
595N

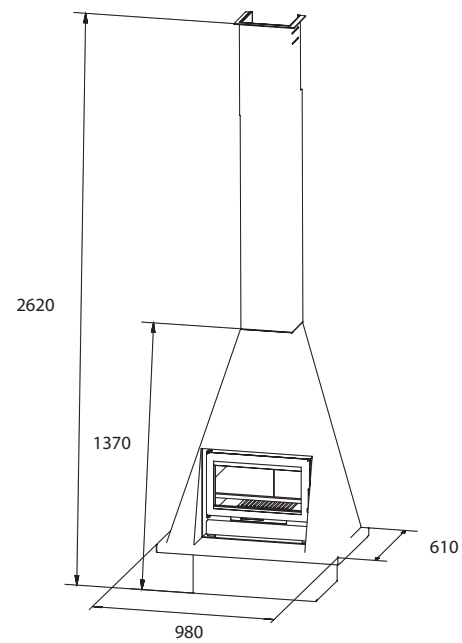

NORDICA 595N



980x2620x610



10.5



71



180



1



300



180





FOGÕES A LENHA  
COCINA DE MADERA  
WOOD COOKERS  
CUSINIÈRE À BOIS







FOGÕES





CLÁSICO

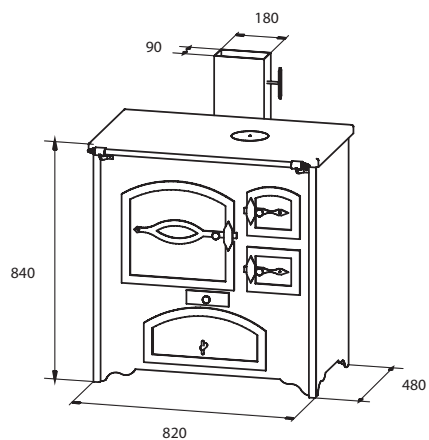

RÚSTICO

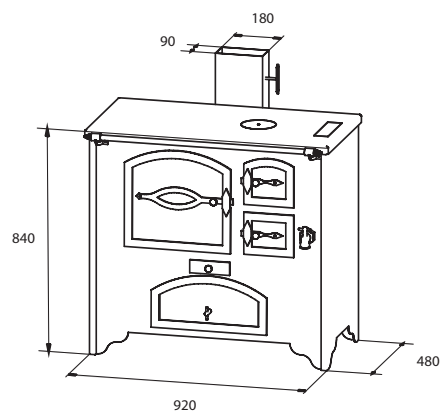

PRESTIGIO

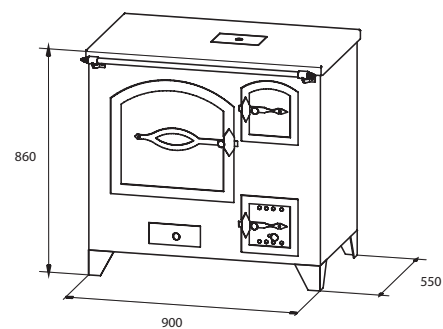

MOD.	MM	KW	%	Ø	mm	M3	KG	LTS	KM	BAR
CLÁSICO	820x840x480	11.25	69	180x90	2	322	140			
RÚSTICO	920x840x480	11.25	69	180x90	2	322	160			
PRESTIGIO	900x860x550	16.4	68	200x100	2	468	263			
PRESTIGIO	900x860x550	16.4	68	200x100	2	468	263	27	13,5	3

ACESSÓRIOS  
 ACCESORIOS  
 ACCESSORIES  
 ACCESSOIRES



1  
 Cesto Redondo  
 Cesta Ronda  
 Log Basket Round  
 Panier Tour



2  
 Cesto Rectangular  
 Cesta Rectángulo  
 Log Basket Rectangle  
 Panier Rectangle



3  
 Cesto Meia Lua  
 Cesta Mitad de la Luna  
 Log Basket Half Moon  
 Panier Demi-Lune



4  
 Cesto Lua  
 Cesta Luna  
 Log Basket Moon  
 Panier Lune

Móvel Vertical 1500/2000mm  
 Móviles Verticales 1500/2000mm  
 Vertical Mobile 1500/2000mm  
 Vertical movable 1500/2000mm



Moldura 4 Lados de 5/8/10cm  
 Marco Integral de 5/8/10cm  
 Full sided Frame 5/8/10cm  
 Cadre Intégral Côtés 5/8/10cm



Moldura em Inox 4 Lados de 5/8/10cm  
 Marco Acero Inoxidable Integral de 5/8/10cm  
 Full sided Stainless Steel Frame 5/8/10cm  
 Cadre en Inox Intégral Côtés 5/8/10cm



Moldura 3 Lados de 5/8cm  
 Marco de 3 Lados de 5/8cm  
 3 sided Frame 5/8cm  
 Cadre 3 Côtés 5/8cm



Moldura em Inox 3 Lados de 5/8cm  
 Marco Acero Inoxidable de 3 Lados de 5/8cm  
 3 sided Stainless Steel Frame 5/8cm  
 Cadre en Inox 3 Côtés 5/8cm



ADF - ANTONINO DIAS FERNANDES, LDA  
ZONA INDUSTRIAL DA RELVINHA  
SARZEDO - APARTADO 55  
3304-909 ARGANIL - PORTUGAL

TELF: +351 235 710 710  
FAX: + 351 235 710 719

ADF@ADF.PT  
WWW.ADF.PT

PT A ADF reserva-se o direito de alterar as características gerais do produto ou aplicar melhorias sem aviso prévio.

ES ADF se reserva el derecho de modificar las características generales del producto o aplicar mejoras sin previo aviso

EN The ADF reserves the right to change the general characteristics of the product or apply enhancements without notice.

FR ADF se réserve le droit de modifier les caractéristiques générales ou mettre en œuvre des améliorations sans préavis



fabricante equipamentos térmicos

[WWW.ADF.EU](http://WWW.ADF.EU)



PME lider



Programa Operacional Regional do Centro



QUADRO DE REFERÊNCIA ESTRATÉGICO NACIONAL

